

Slide gates SPC

The slide gates SPC are used for closing of hoppers with loose and non-adhesive materials. They are applied in places, accessible to manual control.

Description

The slide gate is made of steel S235.

The frame is made of rolled profiles. The plate is made of 6 mm thick sheet and is sealed with graphite packing and is guided in the slide gate frame by means of steel bars. The slide gate is painted with synthetic outer coat, the plate and the inside slide gate surface with ground coat. The sprocket wheel is made of gray cast iron and is mounted on a trapezoidal thread screw. The screw is protected with sheet cover. The slide gate control proceeds with a chain.

Operating conditions

The slide gate in the standard design is used for closing of hopper and containers with loose materials up to temperatures of 150 °C. The slide gate may be mounted only with the flange in horizontal position.

When agreed with the manufacturer, the basic connecting dimensions, or the plate and the sealing bar material can be modified. By using special sealing materials and paints it is possible to use the slide gate for higher temperatures.

Designation

The slide gate is designated:

SPC size

Example of designation with size of flange 400x400 mm:

SPC 400

Other specifications:

Finish undercoat

Finish undercoat + topcoat with RAL color

Technical data

Dimensions and weights

A x B	C	D	L1	L2	n1xd1	n2xd2	n3xm1	v1	Weight [kg]
200 x 200	300	230	472	150	6xØ15	2xM12	1x160	50	42,84
250 x 250	350	230	547	175	6xØ15	2xM12	1x160	75	48,77
315 x 315	415	230	644,5	207,5	6xØ19	2xM16	1x200	92,5	57,59
400 x 400	500	230	772	250	6xØ19	2xM16	1x200	135	67,73
500 x 500	600	230	922	300	9xØ19	3xM16	2x200	85	85,05

Basic dimensions

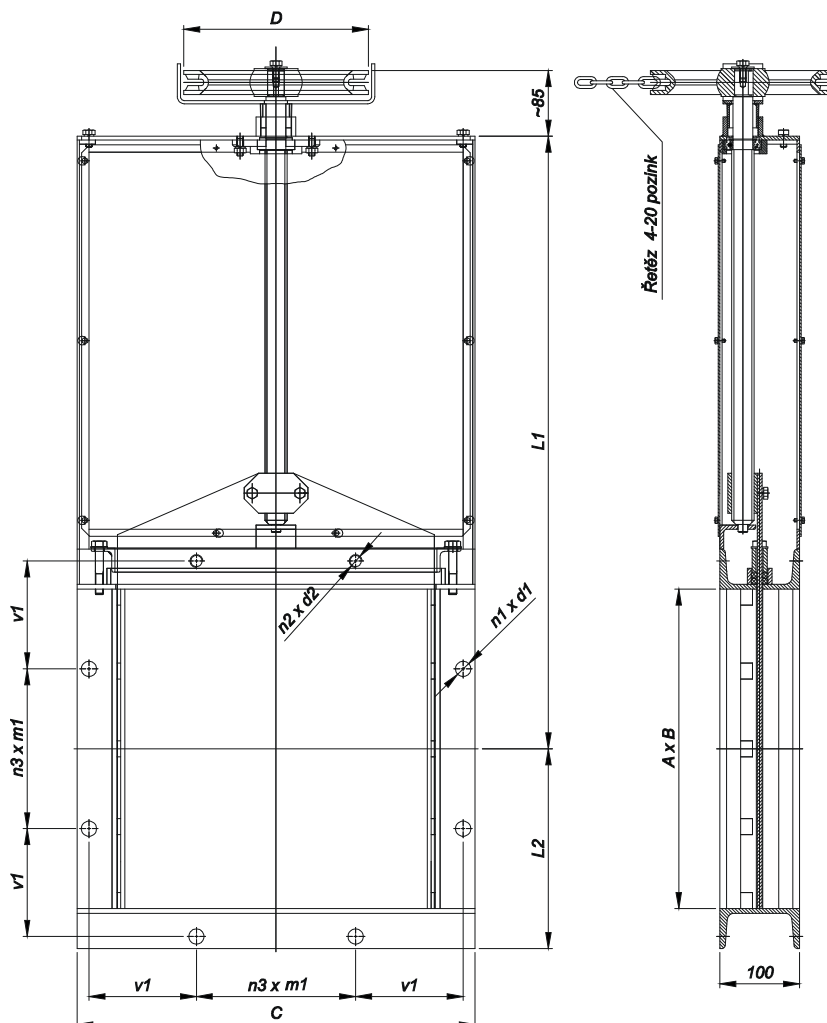

Valid from: 5.2.2014

Elaborated: Pavelka Petr

EKOMETAL - E, spol. s r.o.
Draby 710
566 01 Vysoké Myto
Czech Republic

Tel.: +420 465 423 392
+420 465 423 860
Fax: +420 465 423 385
E-mail: info@ekometal.cz

VAT-No.: CZ60932228
Registration: Regional court Hradec Kralove, section C, insert 5879
Bank: CSOB a.s. - Branch office Vysoké Myto
IBAN: CZ40 0300 0000 0002 5295 4222
SWIFT: CEKOCZPP