

SLIDE GATE SPA

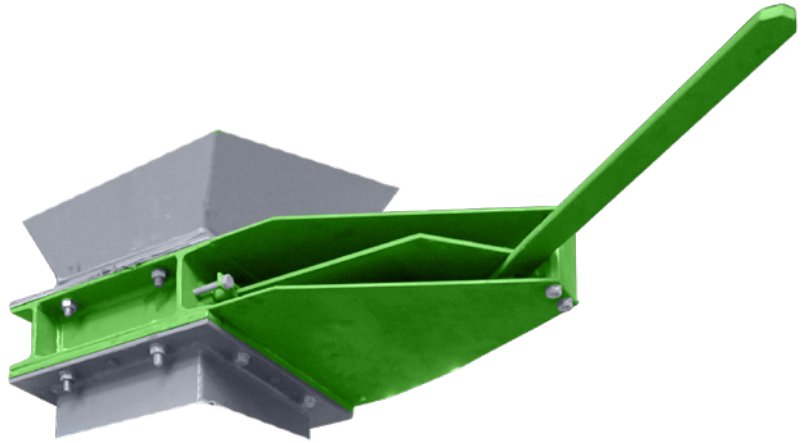

The slide gate SPA is designed for closing the hoppers and storage bunkers with loose and non-adhesive pulverized materials. They are applied in places accessible to manual control by the handwheel. The slide gate is made of rolled profiles with plate of 6 mm thick sheet.

The plate is sealed to the environment with graphite packing and is guided in the slide gate frame by means of steel bars. The slide gates are available in steel grade 11, for more demanding applications from stainless steel materials. They are designed for closing the hoppers and storage bunkers with loose materials up to max. + 150 °C. At customer's request, the basic dimensions of the slide gate can be adjusted. By using special sealing materials and paints it is possible to use the slide gate for higher temperatures.

In standard version, they are surface-finished with undercoat + topcoat in RAL colour as per customer's demand.

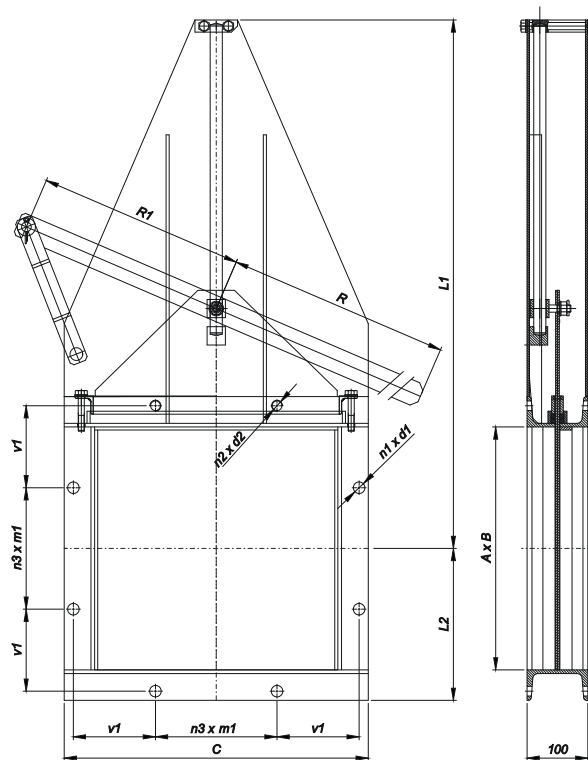

DIMENSIONS AND WEIGHTS

A x B [mm]	C [mm]	L1 [mm]	L2 [mm]	n1xd1 [mm]	n2xd2	n3xm1 [mm]	v1 [mm]	R [mm]	R1 [mm]	Weight [kg]
200 x 200	300	510	150	6xØ15	2xM12	1x160	50	450	190	25,13
250 x 250	350	575	175	6xØ15	2xM12	1x160	75	480	225	30,38
315 x 315	415	722,5	207,5	6xØ19	2xM16	1x200	92,5	610	270	40,08
400 x 400	500	870	250	6xØ19	2xM16	1x200	135	660	340	52,06
500 x 500	600	1060	300	9xØ19	3xM16	2x200	85	900	410	69,61

Example of designation with 200x200 mm flange size: **SPA 200**